

PCT

WORLD INTELLECTUAL PROPERTY ORGANIZATION
International Bureau



INTERNATIONAL APPLICATION PUBLISHED UNDER THE PATENT COOPERATION TREATY (PCT)

<p>(51) International Patent Classification ⁶ : E21B 17/07, 23/01</p>	<p>A1</p>	<p>(11) International Publication Number: WO 00/04271 (43) International Publication Date: 27 January 2000 (27.01.00)</p>
<p>(21) International Application Number: PCT/US99/15991 (22) International Filing Date: 14 July 1999 (14.07.99) (30) Priority Data: 09/115,561 15 July 1998 (15.07.98) US (71)(72) Applicant and Inventor: HUDSON, Leo, D. (US/US); 1838 Renfro Road, Bakersfield, CA 93312 (US). (74) Agents: McCONAGHY, John, D. et al.; Lyon & Lyon LLP, Suite 4700, 623 West Fifth Street, Los Angeles, CA 90071-2066 (US).</p>	<p>(81) Designated States: AB, AL, AM, AT, AU, AZ, BA, BB, BG, BR, BY, CA, CH, CN, CU, CZ, DE, DK, EE, ES, FI, GB, GD, GE, GH, GM, HR, HU, ID, IL, IN, IS, JP, KE, KG, KP, KR, KZ, LC, LK, LR, LS, LT, LU, LV, MD, MG, MK, MN, MW, MX, NO, NZ, PL, PT, RO, RU, SD, SE, SG, SI, SK, SL, TJ, TM, TR, TT, UA, UG, US, UZ, VN, YU, ZA, ZW, ARIPO patent (GH, GM, KE, LS, MW, SD, SL, SZ, UG, ZW), Eurasian patent (AM, AZ, BY, KG, KZ, MD, RU, TJ, TM), European patent (AT, BE, CH, CY, DE, DK, ES, FI, FR, GB, GR, IE, IT, LU, MC, NL, PT, SE), OAPI patent (BF, BJ, CF, CG, CI, CM, GA, GN, GW, ML, MR, NE, SN, TD, TG).</p> <p>Published With international search report.</p>	

BEST AVAILABLE COPY

(54) Title: HYDRAULIC EQUIPMENT FOR EXPANDING TUBULAR ELEMENTS IN WELLS

(57) Abstract

A hydraulic ram (86) for a well including a draw bar (90) with a piston sleeve (122) arranged about the draw bar. The draw bar includes three circumferential shoulders (106) about the outside thereof spaced longitudinally. The draw bar includes a longitudinal passageway (96) and passages (104) extending radially to the outside surface from that longitudinal passage. The piston sleeve (122) includes a series of sections (124) with each section having an annular piston (126) and a skirt (128) extending longitudinally from the annular piston. The annular pistons extend inwardly from the piston sleeve to be slidably sealed against the outside of the draw bar. Similarly, the circumferential shoulders are slidably sealed against the inside of the skirts of the piston sleeve sections. The lower most section (136) includes a ram shoulder (144) to mate with and retain the work as a swedge (146) on the distal end of the draw bar is drawn toward the ram shoulder.

FOR THE PURPOSES OF INFORMATION ONLY

Codes used to identify States party to the PCT on the front pages of pamphlets publishing international applications under the PCT.

AL	Albania	ES	Spain	LS	Lesotho	SI	Slovenia
AM	Armenia	FI	Finland	LT	Lithuania	SK	Slovakia
AT	Austria	FR	France	LU	Luxembourg	SN	Senegal
AU	Australia	GA	Gabon	LV	Latvia	SZ	Swaziland
AZ	Azerbaijan	GB	United Kingdom	MC	Monaco	TD	Chad
BA	Bosnia and Herzegovina	GE	Georgia	MD	Republic of Moldova	TG	Togo
BB	Barbados	GH	Ghana	MG	Madagascar	TJ	Tajikistan
BE	Belgium	CN	China	MK	The former Yugoslav Republic of Macedonia	TM	Turkmenistan
BF	Burkina Faso	GR	Greece	ML	Mali	TR	Turkey
BG	Bulgaria	HU	Hungary	MN	Mongolia	TT	Trinidad and Tobago
BJ	Benin	IE	Ireland	MR	Mauritania	UA	Ukraine
BR	Brazil	IL	Israel	MW	Malawi	UG	Uganda
BY	Belarus	IS	Iceland	MX	Mexico	US	United States of America
CA	Canada	IT	Italy	NE	Niger	UZ	Uzbekistan
CF	Central African Republic	JP	Japan	NL	Netherlands	VN	Viet Nam
CC	Congo	KE	Kenya	NO	Norway	YU	Yugoslavia
CH	Switzerland	KG	Kyrgyzstan	NZ	New Zealand	ZW	Zimbabwe
CI	Côte d'Ivoire	KP	Democratic People's Republic of Korea	PL	Poland		
CM	Cameroon	KR	Republic of Korea	PT	Portugal		
CN	China	KZ	Kazakhstan	RO	Romania		
CU	Cuba	LC	Saint Lucia	RU	Russian Federation		
CZ	Czech Republic	LI	Liechtenstein	SD	Sudan		
DE	Germany	LK	Sri Lanka	SE	Sweden		
DK	Denmark	LR	Liberia	SG	Singapore		
EE	Estonia						

SPECIFICATIONHYDRAULIC EQUIPMENT FOR EXPANDING TUBULAR ELEMENTS IN
WELLS

BACKGROUND OF THE INVENTION

5 The field of the present invention is well drilling and completion equipment.

 Well drilling and completion equipment includes tubular elements which are variously characterized as casing, tubing, liner, hangers, nipples and adapters. Casing, tubing and liner, for universal application, are
10 cylindrical in shape and of a length in compliance with the American Petroleum Institute Standard 5C. Nipples, hangers and adapters are substantially tubular in form, usually circular in cross section with additional possible adaptations such as internal or external threads, circular seals and the like.

15 To insure that the flow of fluids with or without entrained solids is appropriately directed within wells, packers or annular seals are frequently employed to span gaps at radial steps in the tubular construction. Packers are also employed to insure the blockage of pressure from unwanted areas. Additionally, structural support from above frequently is needed for the
20 placement and retention of casing, tubing and liner in the well. Hangers typically are used which employ wedges or other structural devices to grip the inner tubular element. Combinations of packers and hangers are also used.

 One system for hanging a casing, tubing and liner in a well includes expanding the inner tubular outwardly past the elastic limit and into an outer
25 tubular such that the elasticity of the outer tubular draws it tight against the inner tubular. This method and apparatus, including a hydraulic ram and a swedging system, are disclosed in U.S. Patent Application Serial No. 08/947,069, filed October 8, 1997, the disclosure of which is incorporated herein by reference. A further swedging system is disclosed in U.S. Patent

Application Serial N . 09/085,659, filed May 28, 1998, the disclosure of which is incorporated herein by reference.

Hydraulic cylinders have been used to actuate various tools in wells. Such hydraulic cylinders are typically annular in arrangement and include a sliding sleeve associated with a piston. An annular shoulder faces the piston and an outwardly extending passage provides pressure from a central passage in the tool assembly. Such devices are limited by the pressure available through the drill string. Intensifiers have been contemplated for increasing the pressure available.

10 SUMMARY OF THE INVENTION

The present invention is directed to equipment for expanding tubular elements in wells.

In a first separate aspect of the present invention, a hydraulic ram for use in wells may be used for, among other things, drawing swedges through hanger sections and other tubular elements to be expanded in wells. A great deal of force is required to draw a swedge through a tubular element in a well. Further, the equipment must be compatible with the narrow conditions of the well and limited access to pressurize the equipment. A ram including a draw bar with a longitudinal passage extends centrally through a piston sleeve. A plurality of circumferential shoulders about the draw bar cooperate with a plurality of sections defining the piston sleeve which each include a skirt and an annular piston. Each piston cooperates with an adjacent circumferential shoulder to receive hydraulic pressure from the longitudinal passage for generating force in the ram. As the sections are hydraulically arranged in parallel, ram force increases with each added section.

In a second separate aspect of the present invention, a hydraulic ram includes a draw bar with a longitudinal passage extends centrally through a piston sleeve. A plurality of circumferential shoulders about the draw bar cooperate with a plurality of sections defining the piston sleeve which each include a skirt and an annular piston. Each piston cooperates with an adjacent circumferential shoulder to receive hydraulic pressure from the longitudinal passage for generating force in the ram. The circumferential

shoulders include fixed rings with each fixed ring having a first ring and a second ring fixed to the first ring. The first ring and the second ring define an annular channel therebetween facing the draw bar. The draw bar has a circular retainer channel facing the annular channel. A shear element is positioned in the annular channel and the retainer channel.

In a third separate aspect of the present invention, a hydraulic ram includes a draw bar with a longitudinal passage extends centrally through a piston sleeve. A plurality of circumferential shoulders about the draw bar cooperate with a plurality of sections defining the piston sleeve which each include a skirt and an annular piston. Each piston cooperates with an adjacent circumferential shoulder to receive hydraulic pressure from the longitudinal passage for generating force in the ram. The piston sleeve includes a terminal section having a tubular swedge retainer extending longitudinally from the annular terminal piston.

In a fourth separate aspect of the present invention, a hydraulic ram includes a draw bar with a longitudinal passage extends centrally through a piston sleeve. A plurality of circumferential shoulders about the draw bar cooperate with a plurality of sections defining the piston sleeve which each include a skirt and an annular piston. Each piston cooperates with an adjacent circumferential shoulder to receive hydraulic pressure from the longitudinal passage for generating force in the ram. A swedge is fixed to the draw bar. The piston sleeve includes a ram shoulder at the distal end thereof. A tubular element abuts against the ram shoulder. The tubular element includes a portion to be deformed positioned between the ram shoulder and the swedge. A tubular valve element extends about the draw bar below the swedge. The draw bar has at least two bypass passages extending outwardly from the longitudinal passage and spaced longitudinally on the draw bar. The tubular valve element includes a ring seal and has a first position with the ring seal between the longitudinally spaced bypass passages and a second position with the ring seal not between the longitudinally spaced bypass passages. The ring seal includes an annular ring extending outwardly but of no greater circular cross section than the swedge. The tubular element includes a stop displaced from the portion to be deformed which extends

inwardly to interfere with the annular ring with movement of the tubular valve element from the first position to the second position. The longitudinal passage includes a ball seat between the longitudinally spaced bypass passages.

5 In a fifth separate aspect of the present invention, a tool for a well includes a hydraulic ram having a draw bar with a longitudinal passage, and an annular piston sleeve with a ram shoulder. A swedge is fixed to the draw bar and a rotary tool assembly includes a tubular element abutting against the ram shoulder and including a portion to be deformed by the swedge
10 positioned between the ram shoulder and the swedge. The swedge and the tubular element at the portion to be deformed has engaged mating longitudinal splines.

 In a sixth separate aspect of the present invention, any of the foregoing aspects are contemplated to be combined.

15 Accordingly, it is an object of the present invention to provide improved equipment for expanding tubular elements in wells. Other and further objects and advantages will appear hereinafter.

BRIEF DESCRIPTION OF THE FIGURES

 Figure 1 is a partial cross-sectional side view of a hydraulic ram and
20 swedge.

 Figure 2 is a portion of the view of Figure 1 illustrating the elements in greater detail.

 Figure 3 is a partial cross-sectional side view of a second hydraulic ram and swedge with an expandable tubular element.

25 Figure 4 is a partial cross-sectional view of the second hydraulic ram and swedge with the tubular element expanded.

 Figure 5 is a partial cross-sectional view of a circumferential ring assembly in expanded detail.

DETAILED DESCRIPTION OF THE PREFERRED EMBODIMENT

30 Turning in detail to the drawings, hydraulic rams for use in a well are illustrated. The disclosed devices are most useful in systems for expanding tubular devices in wells. The rams would normally be assembled with such a

tubular device in place to be swedged.

The first embodiment illustrated in Figures 1 and 2 includes a ram having a draw bar assembly, generally designated 10. The draw bar assembly 10 has a draw bar 11 with an integral pipe connector 12 at one end and an integral threaded pin 14 at the other. A longitudinal passage 16 extends centrally through the draw bar 11. The outer surface of the draw bar 11 is shown to include a first cylindrical section 18 and a second cylindrical section 20. The second cylindrical section 20 is of reduced diameter, creating a circumferential shoulder 22 at the transition between the two sections 18 and 20. Pressure passages 24, 26 and 28 extend outwardly from the longitudinal passage 16 to the surface of the draw bar 11. There are four of each of the passages 24, 26 and 28 distributed about the circumference of the draw bar 11 at each level. The passages 24, 26 and 28 conveniently extend radially and are shown to be placed equiangularly about the bar 11. The longitudinal passage 16 extends from the upper end of the draw bar 11 at least so far as to communicate with the lower most of the pressure passages 28. Blockage, a valve, an end cap or subsequent equipment beyond the draw bar 11 may limit communication through the longitudinal passage 16 such that pressure can be directed to the pressure passages 24, 26 and 28.

The pressure passage 24 is positioned longitudinally of the draw bar 11 to one side of the circumferential shoulder 22. Circumferential rings 30 and 32 are positioned about the outside cylindrical section 20 of the draw bar 11 longitudinally adjacent to the pressure passages 26 and 28, respectively. These rings define circumferential shoulders. The rings 30 and 32 each have anchor holes 34 extending radially therethrough. Bolts 36 with circular heads 38 having Allen wrench sockets (not shown) are positioned through the anchor holes 34 into tapped holes in the wall of the draw bar 11. Lip seals 40 and 42 are arranged on the inner periphery and outer periphery of each ring 30 and 32 to avoid the passage of pressurized fluid thereby.

A piston sleeve, generally designated 44, is concentrically arranged about the draw bar 11. This piston sleeve 44 is shown to be divided into three sections 46, 48 and 50. The upper section 46 includes an annular piston 52 associated with a skirt 54. The annular piston 52 faces the circumferential

shoulder 22. The piston 52 also extends radially inwardly to be in circumferential sealing engagement with the draw bar 11. A lip seal 56 prevents the passage of pressurized fluid thereby. The skirt 54 is in circumferential sealing engagement with the first cylindrical section 18 through
5 the employment of a lip seal 58 set within the section 18. The skirt 54 has relief ports 60 spaced equiangularly about the sleeve 44 at the same longitudinal placement. The annular piston 52 has external threads.

The lower section 50 also includes an annular piston 62 longitudinally facing the circumferential shoulder defined by the circumferential ring 32. The
10 piston 62 also extends inwardly for circumferential sealing engagement with the draw bar 11 using a lip seal 64. The piston 62 includes a ram shoulder 66. A skirt 68 extends from the annular piston 62 and has an inner threaded connection 70 at its distal end. Relief ports 72 are arranged about the skirt 68 to relieve the volume between the draw bar 10 and the skirt 68 and
15 longitudinally between the circumferential ring 32 and the middle section 48.

The middle section 48 also includes an annular piston 74 and a skirt 76. A lip seal 78 provides sealing between the annular piston 74 and the draw bar 11. Relief ports 80 are also provided. As with the upper annular piston 52, the annular piston 74 includes a threaded outer periphery. As with
20 the lower annular piston 62, the distal end of the skirt 76 includes a threaded inner periphery. In this way, the sections 46, 48 and 50 can be fixed together for cooperative action. Further, the center section 48 can be removed or repeated any number of times with an appropriately configured draw bar 11. As the sections operate in parallel, each additional section increases the force
25 generated by application of pressure to the ram.

A swedge 82 is associated with the lower end of the draw bar 11 and may be slidably positioned thereon. A collar 84 having a threaded connector end is fixed to the threaded pin 14 of the draw bar 11 so as to retain the swedge 82 in place.

30 In operation, a well tool or tubular to be swedged outwardly within a well is positioned between the ram shoulder 66 and the swedge 82 and the device is lowered into the well. When in place, pressure is presented to the longitudinal passage 18 such that it enters the pressure passages 24, 26 and

28. As each corresponding circumferential shoulder 22, 30 and 32 and annular pistons 52, 62 and 74 have a pressure passage 24, 26 and 28, respectively extending therebetween, hydraulic ram force is developed at each piston. The draw bar 11 is drawn upwardly through the ram shoulder 66 until the relief ports 60 come into communication with the pressure passages 24. At this point, pressure within the longitudinal passage 16 is released. The stroke, defined by the relief ports 60, is to be such that the swedging action is complete before pressure is released.

In the second embodiment illustrated in Figures 3, 4 and 5, a hydraulic ram is illustrated with a swedge and an expandable tubular element which is shown to be a nipple. The disclosed hydraulic ram may be expanded and contracted in sections to provide sufficient force for expanding a tool such as illustrated or a portion of a liner or casing within a well.

The hydraulic ram 86 has a draw bar assembly, generally designated 88. The draw bar assembly 88 includes a draw bar 90 with pipe connectors 92 and 94 at either end. A longitudinal passage 96 extends through the center of the draw bar 90. As in the first embodiment, the outer surface of the draw bar 90 includes a first cylindrical section 98 and a second cylindrical section 100 of reduced diameter creating a circumferential shoulder 102. Pressure passages 104 extend outwardly through the wall of the cylindrical section 100. The number of such passages 104 will depend upon the number of active pistons associated with this hydraulic ram 86. Four such passages 104 are equiangularly spaced about the draw bar 90 at each level.

Circumferential shoulders, generally designated 106, are positioned about the draw bar 90. These circumferential shoulders 106 are each defined by a ring assembly fixed relative to the draw bar by a shear element. The ring assembly includes a sealing ring 108 and a retaining ring 110. The sealing ring 108 and the retaining ring 110 are threaded together to act as one element. These ring elements 108 and 110 define an annular channel 112 facing the draw bar 90. The draw bar 90 has circular retainer channels 114 which face the annular channels 112 of the ring assemblies to receive a shear element. A split ring 116 of stainless steel harder than the ring assembly or the draw bar 90 provides the shear element by fitting into the annular

channels 112 and the circular retainer channels 114 at each position of the circumferential shoulders 106. The sealing ring 108 includes circular seals 118 and 120 about the outer and inner peripheries of the ring so as to seal against any longitudinal flow of fluid. The pressure passages 104 are shown to be adjacent to the circumferential shoulders 106.

A piston sleeve, generally designated 122 is positioned about the draw bar 90. The piston sleeve 122 includes a plurality of longitudinally adjacent sections, generally designated 124. These sections 124 are defined by an annular piston 126 and an associated skirt 128. The skirt 128 extends longitudinally from the piston 126 while the piston extends radially inwardly to ride on the outer surface of the draw bar 90. Each piston 126 includes a mating circumferential notch 130 for receiving the distal end of the adjacent skirt 128. Shear retainers 132 extend between the skirts 128 and the piston 126 at the notch 130. As can be observed, these shear retainers 132 are bolts which may be loosely fit within each skirt 128 so that the distal end of each skirt 128 abuts against the end of each notch 130 such that the force of the device is transmitted through the piston sleeve 122 from succeeding skirts 128 and pistons 126. The pistons 126 include an inner circular seal 134 to prevent longitudinal flow beneath the pistons 126. It should be noted that the pressure passages 104 adjacent to the circumferential shoulders 102 are located between such shoulders 102 and the pistons 126 for forcing the pistons downwardly away from the associated adjacent circumferential shoulders 106.

At the lower end of the hydraulic ram 86, the piston sleeve 122 includes a terminal section 136. The terminal section 136 has an annular terminal piston 138 and a terminal skirt 140. In these details, the terminal section 136 is the same as the sections 124. A tubular swedge retainer 142 extends longitudinally from the annular terminal piston 138 in the opposite direction from the terminal skirt 140. This swedge retainer 142 includes a cavity for receiving a swedge therein to the extent that it is released from the tubular element through which it was drawn. The end of the tubular swedge retainer 142 defines a ram shoulder 144 such that the hydraulic ram 86 can operate on a tubular element using the draw bar 90 and the ram shoulder

144.

A swedge 146 is retained on the draw bar 90. The swedge 146 is to be retained longitudinally as well as rotationally on the draw bar 90. The swedge includes a conical portion 148, a cylindrical portion 150 and a splined portion 152. The splined portion 152 is shown to be at the smaller diameter end of the swedge 146. A valve body 154 is threadably joined to the pipe connection 94. The upper shoulder 156 of the valve body 154 may retain the swedge 146 in longitudinal position. Inner splines, a key and keyway or the like may retain the swedge 146 from rotational movement on the drill pipe 90. The valve body 154 includes a central passage 158 therethrough. A pipe connector end 160 may be used for further tubing down hole. The valve body 154 acts as an extension of the draw bar 90 with the central passage 158 acting as an extension of the longitudinal passage 96. In that capacity, the valve includes bypass passages 162 and 164 at spaced longitudinal positions. A ball seal 166 is located in the central passage 158 between the two positions of the bypass passages 162 and 164.

A valve element 168 is positioned on the valve body 154. This valve element 168 has a valve portion 170, a sleeve portion 172 and an annular ring 174. The difference in inner diameter between the valve portion 170 and the sleeve portion 172 creates a shoulder therebetween. A corresponding shoulder on the valve body 154 faces the shoulder on the valve element 168. Because of sealing rings 176 and 178 to either side of the shoulder on the valve body 54, the opposed shoulders define an annular hydraulic cylinder assembly. As pressure passes through the bypass passages 162, the valve element 168 is forced downwardly on the valve body 154. The valve element 168 can assume two positions. The first position is as seen in Figure 3. The second position is as seen in Figure 4. In Figure 3, flow through the bypass passages 162 and 164 is cut off. In Figure 4, the bypass passages 162 and 164 allow flow around the central passage 158. The sleeve portion 172 prevents the flow from exiting from the assembly into the well. A nut at the pipe connector 160 or subsequent equipment may be employed to stop the movement of the valve element 168. Once the bypass passages 162 and 164 are opened, pressure is reduced on the hydraulic cylinder created by these

components.

A tubular component 180 is shown which may be part of a rotary tool assembly, and here is shown to include a drill-in nipple 182 and a liner section 184. The drill-in nipple 182 and liner section 184 are threadably assembled and are contemplated to include such tools as a drill-in liner, underreamer or the like. Such devices are operated through rotation within the well. The drill-in nipple 182 is to be expanded by the swedge 146 to then define a sand control adapter. The nipple 182 includes a thickened portion associated with the swedge 146 and a thin portion able to accommodate the bottom end of the swedge 146 for initial assembly and the annular ring 174. A stop 186 is defined by the shoulder which extends into the threaded end of the nipple 182. The annular ring 174 cannot move out of this area between the thickened portion of the nipple and the stop 186. The inside of the thickened portion of the nipple 182 includes splines 188 which mate with and are, in the initial assembly, engaged with the splined portion 152 of the swedge 146. As such, the nipple 182 and the swedge 146 are rotatably engaged. Thus the entire device is rotatably engaged.

In operation, this second embodiment contemplates the assembly of a liner assembly, or other tubular device associated with the drill-in nipple 182. The device so assembled as illustrated in Figure 3 along with the hydraulic ram 86 suspended from a drill string attached at the pipe connector 92 is lowered into the well. Forced rotational operation can occur because of the splines 152 and 188. At the conclusion of that operation, a ball 190 may be dropped into the line to come to rest at the ball seat 166. Once the ball 190 is in place, substantial pressure can be applied through the longitudinal passage 96.

With pressure applied, flow through the pressure passages 104 will drive the pistons 126 downwardly. As this occurs, the ram shoulder 144 forces the drill-in nipple 182 downwardly around the swedge 146. The drill-in nipple expands outwardly to the casing 192 where it becomes locked in place. The valve element 168 is unable to move because of the annular ring 174 engaging the stop 186. Once the swedge 146 has been pulled into the tubular swedge retainer 142, it becomes free of the drill-in nipple 182. The

drill string can then be pulled upwardly as the annular ring 174 will now clear the interior surface of the drill-in nipple 182. As this occurs, the valve element 168 will drop downwardly to expose the bypass passages 162 and 164. The either full or residual fluid pressure within the drill string will operate on the annular hydraulic cylinder of the valve body 154 and valve element 168 to open these passages. With the opening of the bypass passages 162 and 164, the drill string can be emptied of fluid as the components are removed, leaving the drill-in nipple 182 now acting as a sand control adapter associated with the assembled liner and tools extending further into the well.

Accordingly, improved hydraulic equipment for expanding tubular elements is disclosed for in well use. While embodiments and applications of this invention have been shown and described, it would be apparent to those skilled in the art that many more modifications are possible without departing from the inventive concepts herein. The invention, therefore is not to be restricted except in the spirit of the appended claims.

Claims:

1. A hydraulic ram for a well, comprising
a draw bar assembly including a draw bar with a longitudinal passage,
a plurality of circumferential shoulders about the outside of the draw bar
5 spaced longitudinally along the draw bar and pressure passages extending
from the longitudinal passage to the outside of the draw bar;
a piston sleeve about the draw bar and including a plurality of
longitudinally adjacent sections, the sections having annular pistons and skirts
extending longitudinally from the annular pistons, respectively, the annular
10 pistons extending radially inwardly from the skirt and being in circumferential
sealing engagement with the draw bar, the annular pistons being spaced
along the piston sleeve to face the circumferential shoulders, respectively,
with the pressure passages being between the annular pistons and the
circumferential shoulders, respectively, the circumferential shoulders being in
15 circumferential sealing engagement with the skirt.
2. The hydraulic ram of claim 1, a plurality of the circumferential
shoulders each having a ring fixed about the draw bar.
3. The hydraulic ram of claim 2, each fixed ring having at least one
shear element extending into engagement with the fixed ring and with the
20 draw bar.
4. The hydraulic ram of claim 3, each fixed ring further having a
first ring and a second ring fixed to the first ring, the first ring and the second
ring defining an annular channel therebetween facing the draw bar, the draw
bar having a circular retainer channel facing the annular channel, the shear
25 element being a split ring positioned in the annular channel and the retainer
channel.
5. The hydraulic ram of claim 4, each shear element being of
harder material than the first and second rings.
6. The hydraulic ram of claim 5, each of one of the first and second
30 rings having a first ring seal about the inner periphery thereof and each of one
of the first and second rings having a second ring seal about the outer
periphery thereof.

7. The hydraulic ram of claim 1, a plurality of the pistons each having a mating circumferential notch receiving the skirt of an adjacent section.

5 8. The hydraulic ram of claim 7 further comprising shear retainers extending between the skirt and the adjacent mating circumferential notch, respectively.

10 9. The hydraulic ram of claim 1, the piston sleeve including a terminal section having an annular terminal piston, a terminal skirt extending longitudinally from the annular terminal piston in one direction and a tubular swedge retainer extending longitudinally from the annular terminal piston in the other direction, the annular terminal piston extending radially inwardly from the terminal skirt and being in circumferential sealing engagement with the draw bar, the annular terminal piston being positioned on the piston sleeve to face one of the circumferential shoulders with at least one of the
15 pressure passages being between the annular terminal piston and the adjacent circumferential shoulder, the tubular swedge retainer including a cavity for receiving the swedge substantially therein.

10. The hydraulic ram of claim 9, the tubular swedge retainer including a ram shoulder at the distal end thereof.

20 11. The hydraulic ram of claim 1 further comprising a swedge fixed to the draw bar, the piston sleeve including a tubular swedge retainer with a ram shoulder at the distal end thereof, the tubular swedge retainer including a cavity for receiving the swedge substantially therein.

25 12. The hydraulic ram of claim 11 further comprising a tubular element abutting against the ram shoulder, the tubular element including a portion to be deformed positioned between the ram shoulder and the swedge, the swedge and the tubular element having mating longitudinal splines engaged.

13. The hydraulic ram of claim 12 further comprising
a tubular valve element extending about the draw bar below the
swedge, the draw bar having at least two bypass passages extending
outwardly from the longitudinal passage and spaced longitudinally on the
draw bar, the tubular valve element including a ring seal, the tubular valve
5 element having a first position with the ring seal between the longitudinally
spaced bypass passages and a second position with the ring seal not
between the longitudinally spaced bypass passages, the ring seal including
an annular ring extending outwardly but of no greater circular cross section
10 than the swedge, the tubular element including a stop displaced from the
portion to be deformed, the annular ring being between the portion to be
deformed and the stop, the stop extending inwardly to interfere with the
annular ring with movement of the tubular valve element from the first position
to the second position, the longitudinal passage including a ball seat between
15 the longitudinally spaced bypass passages.

14. A tool for a well comprising
a hydraulic ram including a draw bar with a longitudinal passage, and
an annular piston sleeve with a ram shoulder;
a swedge fixed to the draw bar;
20 a rotary tool assembly including a tubular element abutting against the
ram shoulder, the tubular element including a portion to be deformed by the
swedge positioned between the ram shoulder and the swedge, the swedge
and the tubular element at the portion to be deformed having engaged mating
longitudinal splines.

25 15. The tool for a well of claim 14 further comprising
a tubular valve element extending about the draw bar below the
swedge, the draw bar having at least two bypass passages extending
outwardly from the longitudinal passage and spaced longitudinally on the
draw bar, the tubular valve element including a ring seal, the tubular valve
30 element having a first position with the ring seal between the longitudinally
spaced bypass passages and a second position with the ring seal not
between the longitudinally spaced bypass passages, the ring seal including

an annular ring extending outwardly but of no greater circular cross section than the swedge, the tubular element including a stop displaced from the portion to be deformed, the annular ring being between the portion to be deformed and the stop, the stop extending inwardly to interfere with the annular ring with movement of the tubular valve element from the first position to the second position, the longitudinal passage including a ball seat between the longitudinally spaced bypass passages.

16. The tool for a well of claim 15, the piston sleeve including a tubular swedge retainer with the ram shoulder at the distal end thereof, the tubular swedge retainer including a cavity for receiving the swedge substantially therein.

BEST AVAILABLE COPY

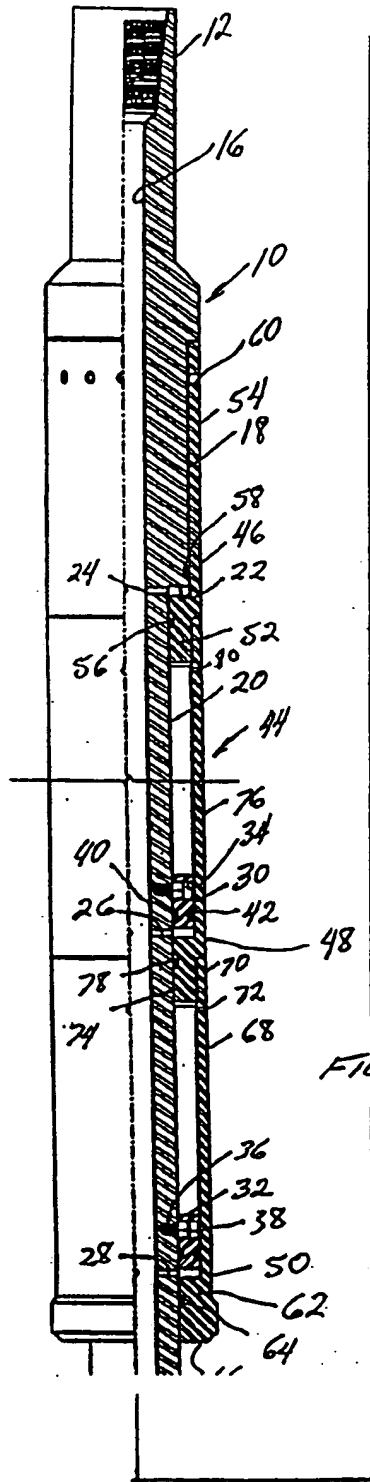

FIG. 1A

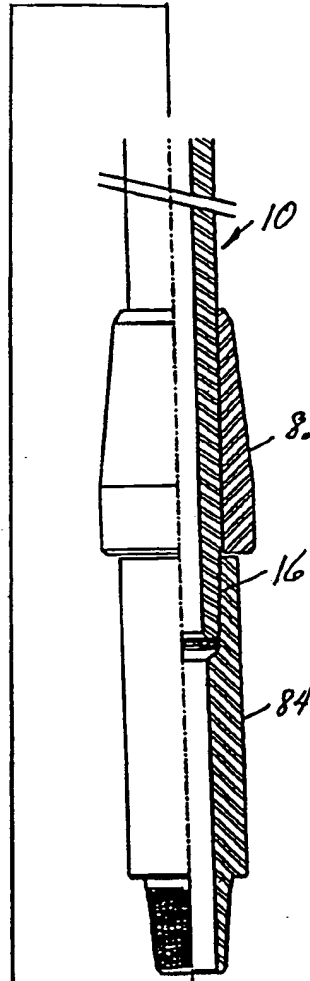

FIG. 1B

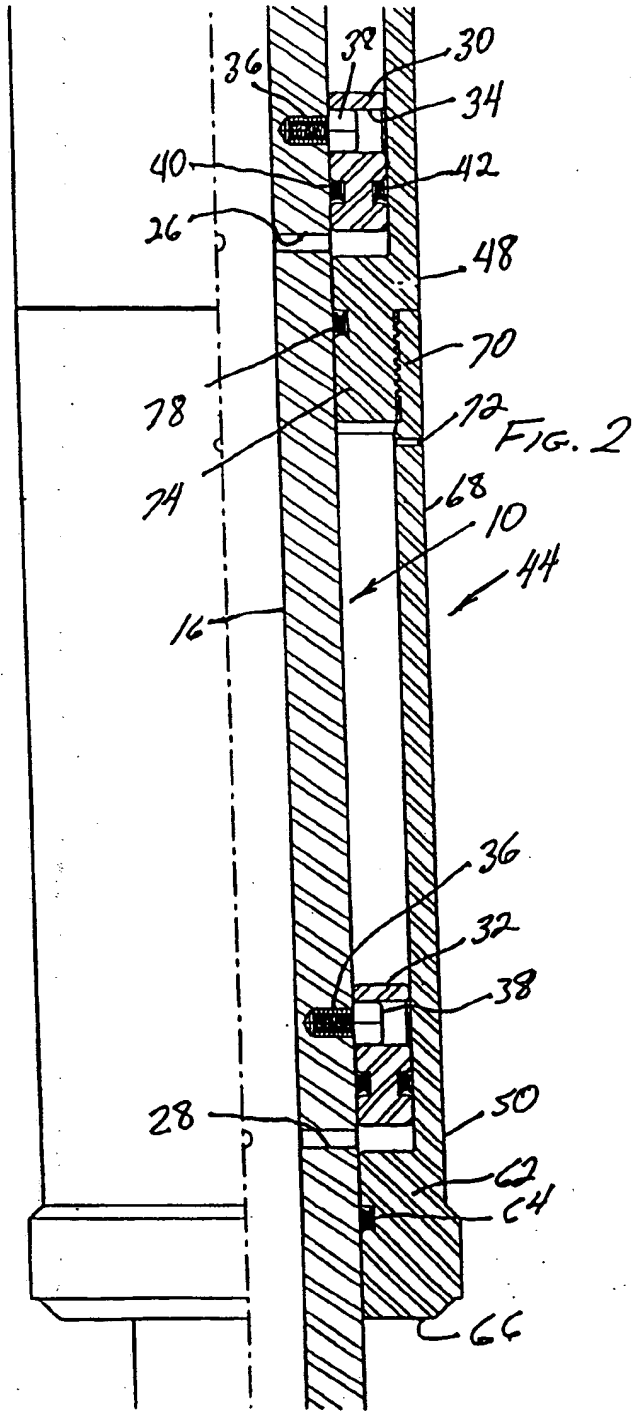

FIG. 2

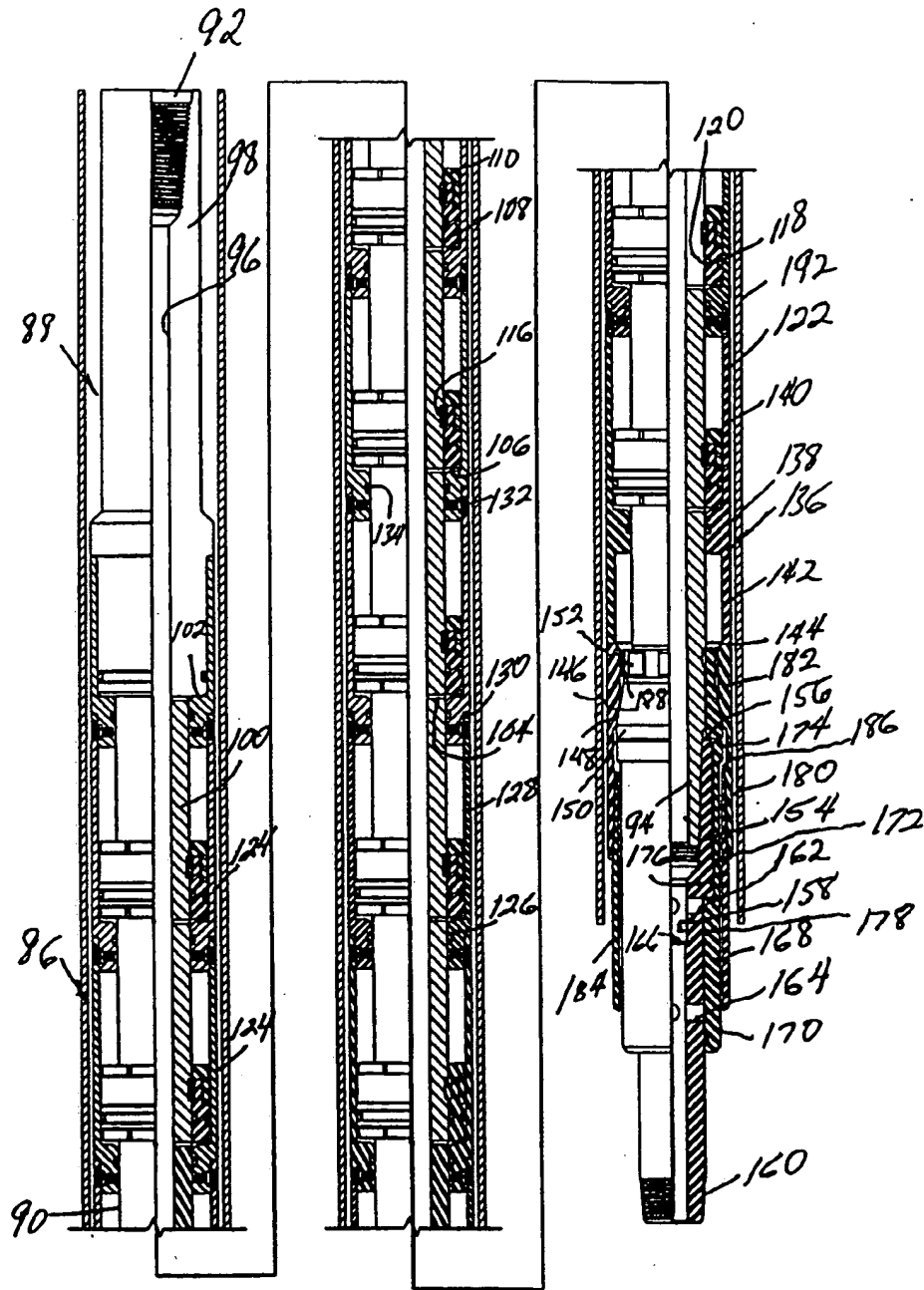

FIG. 3

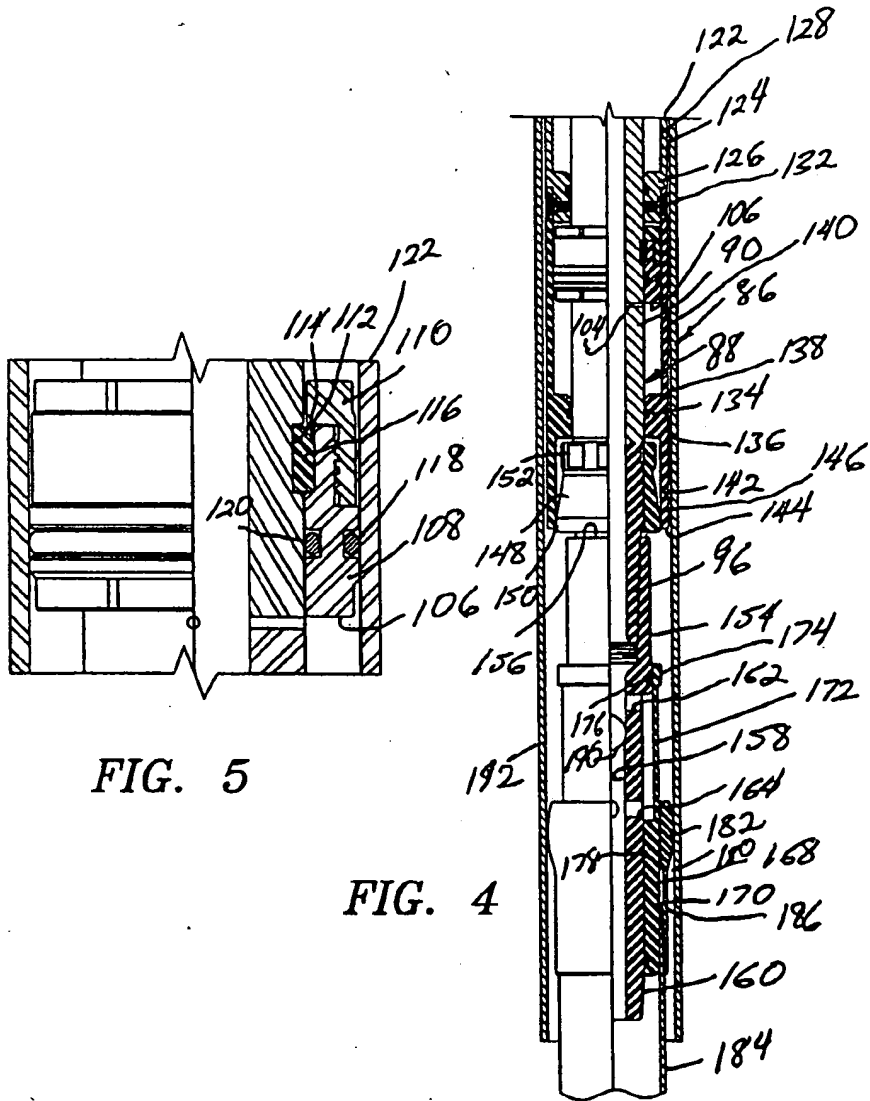



FIG. 5

FIG. 4

INTERNATIONAL SEARCH REPORT

International application No.
PCT/US99/15991

A. CLASSIFICATION OF SUBJECT MATTER IPC(6) : E21B 17/07, 23/01 US CL : 166/98, 207, 212 According to International Patent Classification (IPC) or to both national classification and IPC																				
B. FIELDS SEARCHED Minimum documentation searched (classification system followed by classification symbols) U.S. : 166/98, 206, 207, 212, 301, 217 Documentation searched other than minimum documentation to the extent that such documents are included in the fields searched Electronic data base consulted during the international search (name of data base and, where practicable, search terms used)																				
C. DOCUMENTS CONSIDERED TO BE RELEVANT																				
Category*	Citation of document, with indication, where appropriate, of the relevant passages	Relevant to claim No.																		
X	US 2,377,249 A (LAWRENCE) 29 May 1945 (29/05/45), see figures 1-3.	1,2,7																		
Y		3,8																		
Y	US 4,767,310 A (NEUMANN et al) 30 August 1988 (30/08/88), see column 2, lines 28-29.	3,8																		
A	US 5,070,941 A (KILGORE) 10 December 1991 (10/12/91), see the entire patent.	1-8																		
A	US 3,412,565 A (LINDSEY et al) 26 November 1968 (26/11/68), see the entire patent.	9-16																		
A	DL 203,767 A (SCHWARZMEIER et al) 02 November 1983 (02/11/83), see figures 1-2.	1-16																		
A	US 3,746,091 A (OWEN et al) 17 July 1973 (17/07/73), see the	1-16																		
<input checked="" type="checkbox"/> Further documents are listed in the continuation of Box C. <input type="checkbox"/> See patent family annex.																				
<table border="0"> <tr> <td>* Special categories of cited documents:</td> <td>"T"</td> <td>later document published after the international filing date or priority date and not in conflict with the application but cited to understand the principle or theory underlying the invention</td> </tr> <tr> <td>"A" document defining the general state of the art which is not considered to be of particular relevance</td> <td>"X"</td> <td>document of particular relevance; the claimed invention cannot be considered novel or cannot be considered to involve an inventive step when the document is taken alone</td> </tr> <tr> <td>"E" earlier document published on or after the international filing date</td> <td>"Y"</td> <td>document of particular relevance; the claimed invention cannot be considered to involve an inventive step when the document is considered with one or more other such documents, such combination being obvious to a person skilled in the art</td> </tr> <tr> <td>"L" document which may throw doubt on priority claim(s) or which is cited to establish the publication date of another citation or other special reason (as specified)</td> <td>"A"</td> <td>document member of the same patent family</td> </tr> <tr> <td>"O" document referring to an oral disclosure, use, exhibition or other means</td> <td></td> <td></td> </tr> <tr> <td>"P" document published prior to the international filing date but later than the priority date claimed</td> <td></td> <td></td> </tr> </table>			* Special categories of cited documents:	"T"	later document published after the international filing date or priority date and not in conflict with the application but cited to understand the principle or theory underlying the invention	"A" document defining the general state of the art which is not considered to be of particular relevance	"X"	document of particular relevance; the claimed invention cannot be considered novel or cannot be considered to involve an inventive step when the document is taken alone	"E" earlier document published on or after the international filing date	"Y"	document of particular relevance; the claimed invention cannot be considered to involve an inventive step when the document is considered with one or more other such documents, such combination being obvious to a person skilled in the art	"L" document which may throw doubt on priority claim(s) or which is cited to establish the publication date of another citation or other special reason (as specified)	"A"	document member of the same patent family	"O" document referring to an oral disclosure, use, exhibition or other means			"P" document published prior to the international filing date but later than the priority date claimed		
* Special categories of cited documents:	"T"	later document published after the international filing date or priority date and not in conflict with the application but cited to understand the principle or theory underlying the invention																		
"A" document defining the general state of the art which is not considered to be of particular relevance	"X"	document of particular relevance; the claimed invention cannot be considered novel or cannot be considered to involve an inventive step when the document is taken alone																		
"E" earlier document published on or after the international filing date	"Y"	document of particular relevance; the claimed invention cannot be considered to involve an inventive step when the document is considered with one or more other such documents, such combination being obvious to a person skilled in the art																		
"L" document which may throw doubt on priority claim(s) or which is cited to establish the publication date of another citation or other special reason (as specified)	"A"	document member of the same patent family																		
"O" document referring to an oral disclosure, use, exhibition or other means																				
"P" document published prior to the international filing date but later than the priority date claimed																				
Date of the actual completion of the international search 12 SEPTEMBER 1999		Date of mailing of the international search report 21 OCT 1999																		
Name and mailing address of the ISA/US Commissioner of Patents and Trademarks Box PCT Washington, D.C. 20231 Facsimile No. (703) 305-3230		Authorized officer  Telephone No. (703) 308-2168																		

INTERNATIONAL SEARCH REPORT

International application No.
PCT/US99/15991

C (Continuation). DOCUMENTS CONSIDERED TO BE RELEVANT		
Category*	Citation of document, with indication, where appropriate, of the relevant passages	Relevant to claim No.
A	SU 1,686,125 A (IVANOV) 23 October 1991 (23/10/91), see figures 1-3.	9-16

INTERNATIONAL SEARCH REPORT

International application No.
PCT/US99/15991**Box I Observations where certain claims were found unsearchable (Continuation of Item 1 of first sheet)**

This international report has not been established in respect of certain claims under Article 17(2)(a) for the following reasons:

1. Claims Nos.:
because they relate to subject matter not required to be searched by this Authority, namely:
2. Claims Nos.:
because they relate to parts of the international application that do not comply with the prescribed requirements to such an extent that no meaningful international search can be carried out, specifically:
3. Claims Nos.:
because they are dependent claims and are not drafted in accordance with the second and third sentences of Rule 6.4(a).

Box II Observations where unity of invention is lacking (Continuation of Item 2 of first sheet)

This International Searching Authority found multiple inventions in this international application, as follows:

Please See Extra Sheet.

1. As all required additional search fees were timely paid by the applicant, this international search report covers all searchable claims.
2. As all searchable claims could be searched without effort justifying an additional fee, this Authority did not invite payment of any additional fee.
3. As only some of the required additional search fees were timely paid by the applicant, this international search report covers only those claims for which fees were paid, specifically claims Nos.:
4. No required additional search fees were timely paid by the applicant. Consequently, this international search report is restricted to the invention first mentioned in the claim; it is covered by claims Nos.:

Remark on Protest

The additional search fees were accompanied by the applicant's protest.

No protest accompanied the payment of additional search fees.

INTERNATIONAL SEARCH REPORT

International application No.
PCT/US99/15991

BOX II. OBSERVATIONS WHERE UNITY OF INVENTION WAS LACKING

This ISA found multiple inventions as follows:

This application contains the following inventions or groups of inventions which are not so linked as to form a single inventive concept under PCT Rule 13.1. In order for all inventions to be searched, the appropriate additional search fees must be paid.

Group I, claim(s) 1-13, drawn to a hydraulic ram for a well.

Group II, claim(s) 14-16, drawn to a tool for a well.

The inventions listed as Groups I and II do not relate to a single inventive concept under PCT Rule 13.1 because, under PCT Rule 13.2, they lack the same or corresponding special technical features for the following reasons: The special technical feature of the claims of Group I is the provision of a plurality of circumferential shoulders on the outside of the draw bar and a plurality of annular pistons on the piston sleeve whereas the special technical feature of the claims of Group II is the provision of a swedge on the draw bar and a rotary tool assembly including a portion to be deformed by the swedge.